

PARIS

Site Furnishings • Outdoor Fitness



"Roller-Fit" 1-Person Leg Press

Inground Model: 78001002

Surface Mount Model: 78001002SM

Rev. 20Jun13

259 Third Concession Rd, PO Box 490
Princeton, ON N0J 1V0
Toll Free: 1-800-387-6318
Phone: (519) 458-4882
Fax: (519) 458-8087
www.peml.com

DOUBLE LEG PRESS
SINGLE LEG PRESS

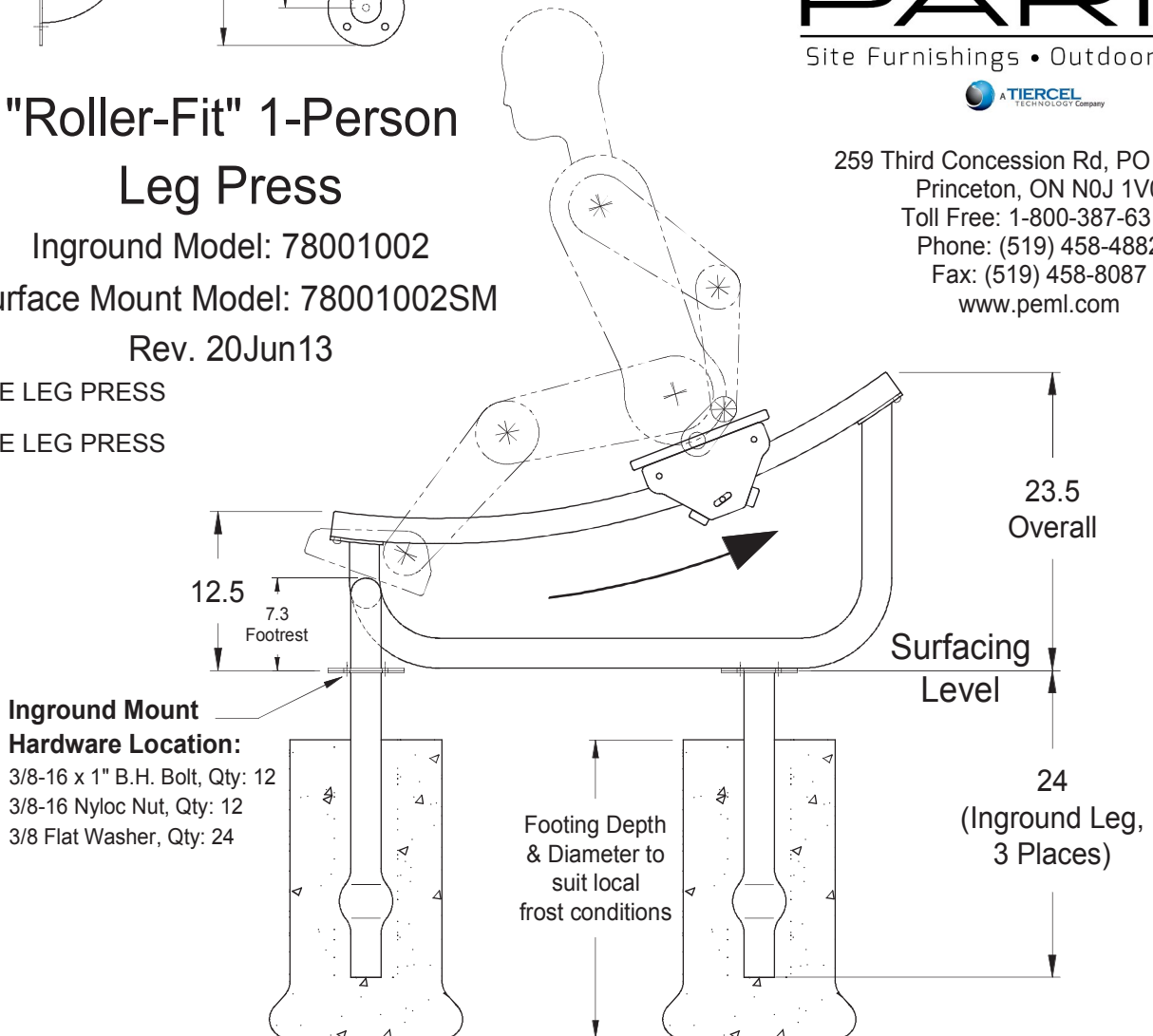

Surface Mounting Notes:

For Surface Mounting version the Inground Legs are omitted. Anchoring hardware is not included as it is impossible to foresee all possible mounting surface conditions. Therefore, anchoring hardware "Types" only are suggested for a typical concrete pad. The concrete should be fully cured and a minimum of 3-1/2 inches thick to properly anchor this product.

Suggested Surface Mounting Anchoring Hardware:

7/16" to 1/2" diameter x 3" long, expanding wedge bolts, 6 minimum (12 maximum) required.

Note: The actual 78001002 assembly should be used as a template to locate the anchor holes.