

PARIS

Site Furnishings • Outdoor Fitness
Toll-Free: 1-800-387-6318

NOTES:
1. FINISH:
MEDIA BLAST TO SP10, HIGH HEAT
SILICONE POWDER COAT BLACK

ITEM NO.	PART NUMBER	DESCRIPTION	QTY.
1	304-595	FR, SURROUND SUB-ASS'Y - PARKS CANADA	1
2	304-596	FR, GRILL SUB-ASS'Y	1
3	116-854	FR, BRACKET BAR	1
4	116-855	FR, GROUND STAKE	2
5	254-061	.25 X DIA 1.0 FENDER WASHER, SS	2
6	254-078	.25 LOCKWASHER, SS	2
7	250-589	1/4-20 X 3/4 BHCS, SS	2

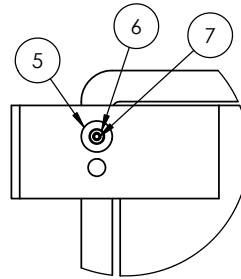
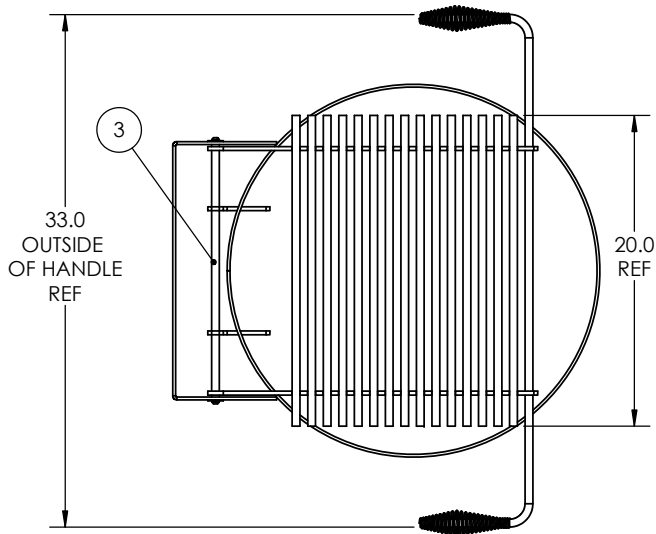

DETAIL A
SCALE 1:4

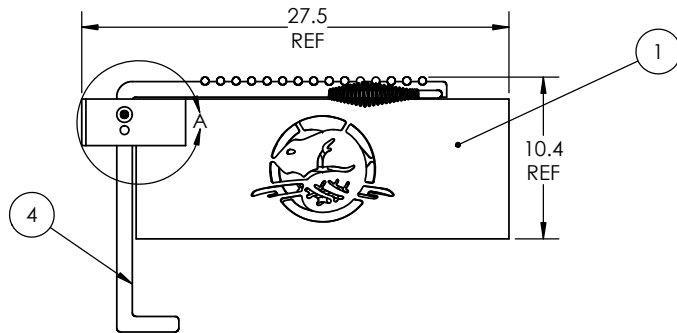
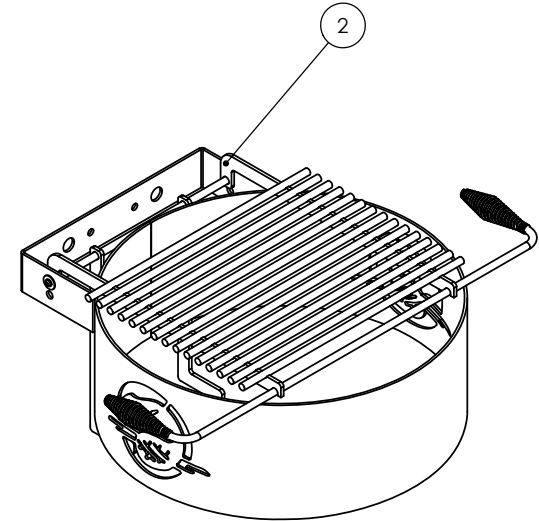

SHIP 116-855 (ITEM 4) SEPERATELY

UNLESS OTHERWISE SPECIFIED
DO NOT SCALE DRAWING
INTERPRET DIMENSIONS AND TOLERANCES
PER ASME Y14.5M-1994
DIMENSIONS ARE IN INCHES
TOLERANCES APPLY AS SHOWN BELOW
DECIMALS: .015" OVER .010" OVER .010"

1 PL DEC	± 0.125	± 0.250
2 PL DEC	± 0.062	± 0.125
3 PL DEC	± 0.031	± 0.031
ANGLES	± 1.5°	

THIRD ANGLE PROJECTION

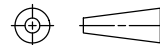

PROPRIETARY
NO PART OF THIS DOCUMENT MAY BE REPRODUCED, STORED IN A RETRIEVAL SYSTEM, OR TRANSMITTED IN ANY FORM, WITHOUT THE WRITTEN PERMISSION OF Tiercel Technology Corporation.

TITLE
FIRE RING W/FLIP BACK GRILL

SIZE **B** DRAWING NO. **464-330** REVISION **0**

REV.	DESCRIPTION	DATE	BY	ECO #

DRAWN BY: C. PADDOEN DATE: 07/04/2017 SCALE: 1:12 WEIGHT: 62.98 lbs SHEET 1 OF 1